

1 2 3 4 5 6

A

A

B

B

C

C

D

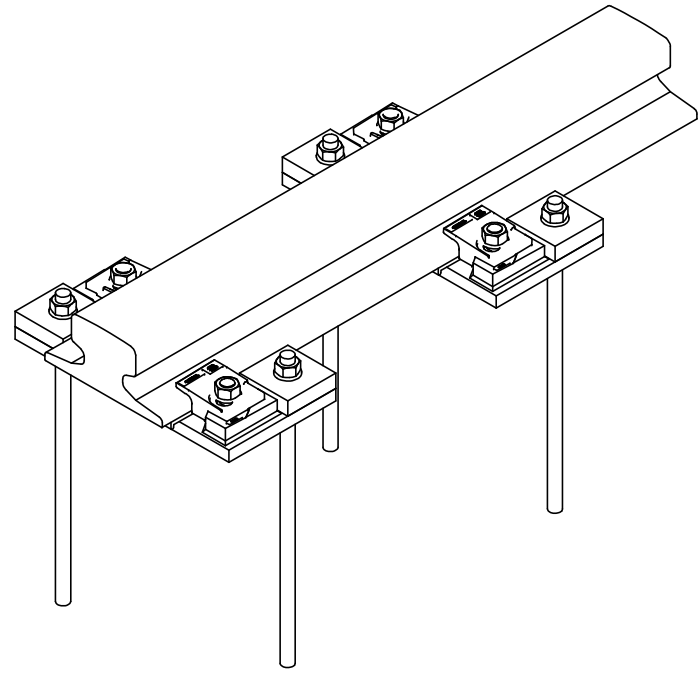
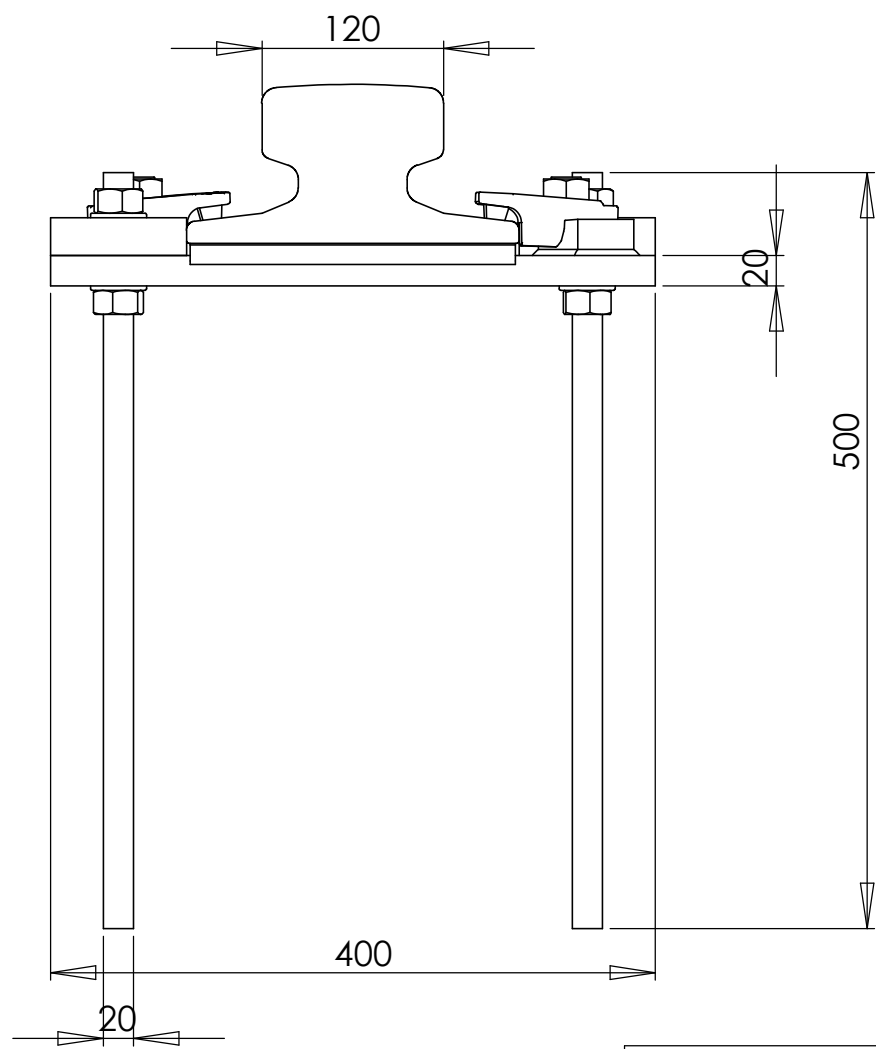

UNLESS OTHERWISE SPECIFIED: DIMENSIONS ARE IN MILLIMETERS SURFACE FINISH: TOLERANCES: LINEAR: ANGULAR:		FINISH: BRUTS DE LAMINAGE		DEBUR AND BREAK SHARP EDGES	
NAME	SIGNATURE	DATE			
DRAWN: ORODEL		04/11/2009			
CHK'D: ORODEL		04/11/2009			
APPV'D					
MFG					
Q.A			MATERIAL: S235JRG2		

Unité de mesure: KG	REVISION: A
ASECOM RAILS	
Assemblage PLATINES INDIVIDUELLES	
DWG NO.1	A4
SHEET 1 OF 1	