

# 2524/20

## Gantrail Bolted Fixing

www.gantrail.com



**GANTRAIL**  
A world of crane rail expertise

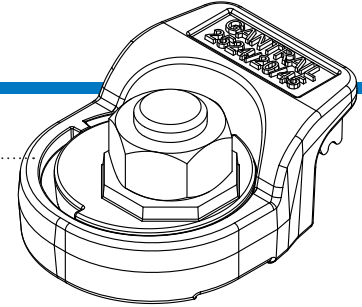

# 2524/20

The GANTRAIL 2524/20 adjustable crane rail clip is designed to fix heavy rails in the most arduous applications. It can withstand a horizontal force from the rail of 125kN (12.7 tonnes). Its low profile allows it to be used with cranes that are fitted with guide rollers.

### SPECIFICATIONS:

BOLT GRADE	8.8	10.9
MAX SIDE LOAD (kN)	125	140
BOLT TORQUE (Nm)	600	750

20mm HORIZONTAL RAIL ADJUSTMENT

### DIMENSIONS (mm):

REF NO.	X	Y (FULL NUT)	Y (THIN NUT)	Z	WEIGHT kg
2524/20/45	45	55	50	32	1.1

\*weight without nut, bolt and washer.

### FEATURES

- The clip has a unique self-tightening mechanism (patent pending)
- The unique design ensures that incorrect installation is avoided
- The clip is bolted to the rail support.
- The two main parts are locked together on tightening the nut.
- A special vulcanised rubber block applies a controlled force to the rail.

### COMPONENTS

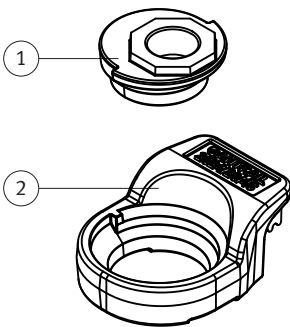

1. Clip cam
2. Clip body with integral rubber block

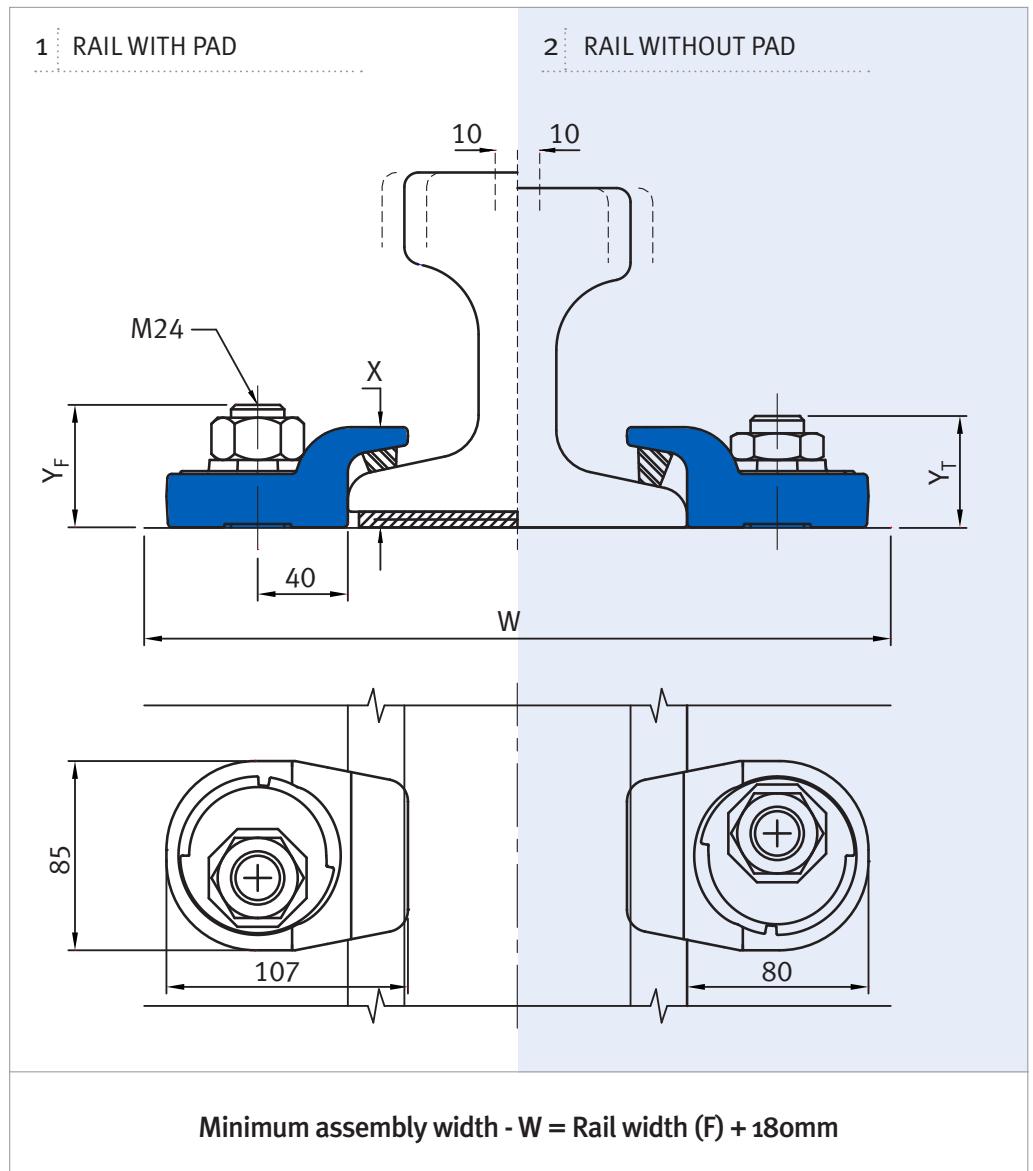

# 2524/20

## Gantrail Bolted Fixing

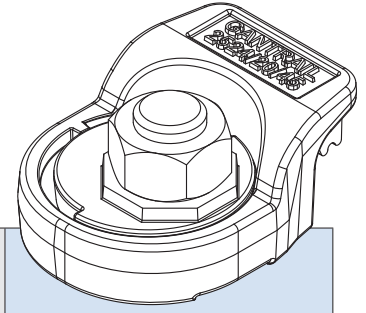

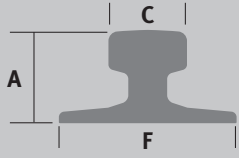
	F mm	C mm	A mm	1. CLIP REFERENCE FOR PAD MOUNTED RAIL	2. CLIP REFERENCE FOR RAIL WITHOUT PAD
68 kg	152	75	186	2524/20/45	2524/20/45
73 kg	146	70	157	2524/20/45	2524/20/45
86 kg	165	102	102	2524/20/45	2524/20/45
A120	220	120	105	2524/20/45	2524/20/45
A150	220	150	150	2524/20/45	2524/20/45
MRS 73	146	70	157	2524/20/45	2524/20/45
MRS 86	165	102	102	2524/20/45	2524/20/45
MRS 87A	152	102	152	2524/20/45	2524/20/45
CR 73	140	100	135	2524/20/45	2524/20/45
CR 100	140	100	135	2524/20/45	2524/20/45
QU 120	150	100	150	2524/20/45	2524/20/45
ISCR 120	170	120	170	2524/20/45	2524/20/45
SP 120	170	120	170	2524/20/45	2524/20/45
171 CR	152	103	152	2524/20/45	2524/20/45
175 CR	152	102	152	2524/20/45	2524/20/45

**THIS CLIP CAN BE USED FOR A WIDER SELECTION OF RAILS THAN ILLUSTRATED.**  
Please contact GANTRAIL for the full range of possible rails. All rails can be fastened with bolted or welded base clips. GANTRAIL may change or improve their products and also alter specifications without notice.

### INSTALLATION INSTRUCTIONS:

The hexagon headed fixing bolt can be inserted from above or below the supporting structure – see adjacent configurations.

**TIGHTENING TORQUE**  
Grade 8.8 bolt 600Nm  
Grade 10.9 bolt 750Nm  
Please contact GANTRAIL for full installation instructions.

### BOLT CONFIGURATIONS

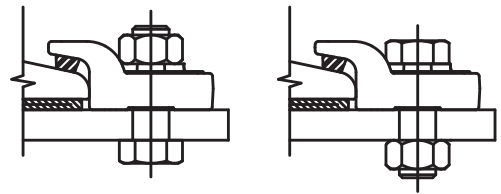

A world of crane rail expertise.

[www.gantrail.com](http://www.gantrail.com)



**Gantry Railing Ltd**  
Sudmeadow Road  
Hempsted  
Gloucester GL2 5HG  
ENGLAND

Tel: +44 (0) 1452 300688  
Fax: +44 (0) 1452 300198  
E-mail: [info@gantrail.com](mailto:info@gantrail.com)

**Gantrail (Middle East) Ltd**  
P O Box 61428  
Jebel Ali Free Zone  
Dubai  
United Arab Emirates

Tel: +971 4 8812 935  
Fax: +971 4 8812 936  
E-mail: [gme@gantrail.com](mailto:gme@gantrail.com)



Certificate No. 5180