

# 9216/08

## Gantrail Welded Base Fixing

www.gantrail.com



**GANTRAIL**  
A world of crane rail expertise

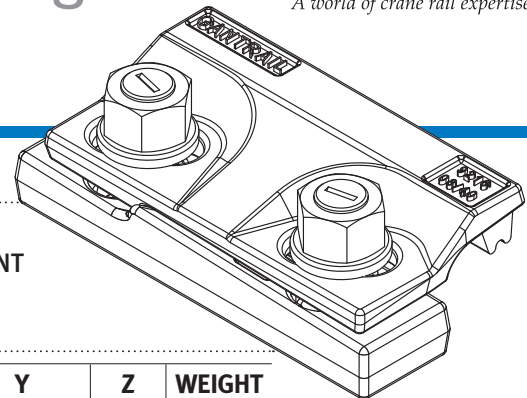

The GANTRAIL 9216/08 adjustable crane rail clip is designed to fix heavy rails, on narrow girders, in the most arduous applications. It can withstand a horizontal force from the rail of 165kN (16.8 tonnes). Its low profile allows it to be used with cranes that are fitted with guide rollers.

### SPECIFICATIONS:

**MAX SIDE LOAD 165kN**  
**8mm HORIZONTAL RAIL ADJUSTMENT**

### DIMENSIONS (mm):

REF NO.	X	Y (FULL NUT)	Y (THIN NUT)	Z	WEIGHT kg
9216/08/40	40	49	46	28	1.35
9216/08/44	44	49	46	28	1.37

9216/08

### FEATURES

- The proven design has been used successfully for many years throughout the world.
- The clip is welded to the rail support. No access is required from below.
- The two main parts are locked together on tightening the grade 8.8 bolts.
- The clip has a self-tightening mechanism.
- A special vulcanised rubber block applies a controlled force to the rail.

### COMPONENTS

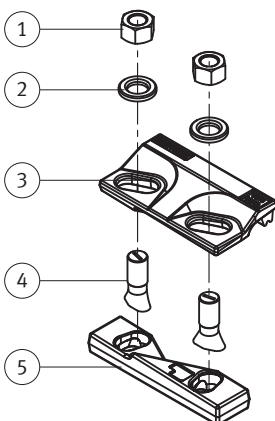

1. Nuts
2. Hardened washers
3. Clip cap with integral rubber block
4. M16 Captive bolts
5. Weldable base

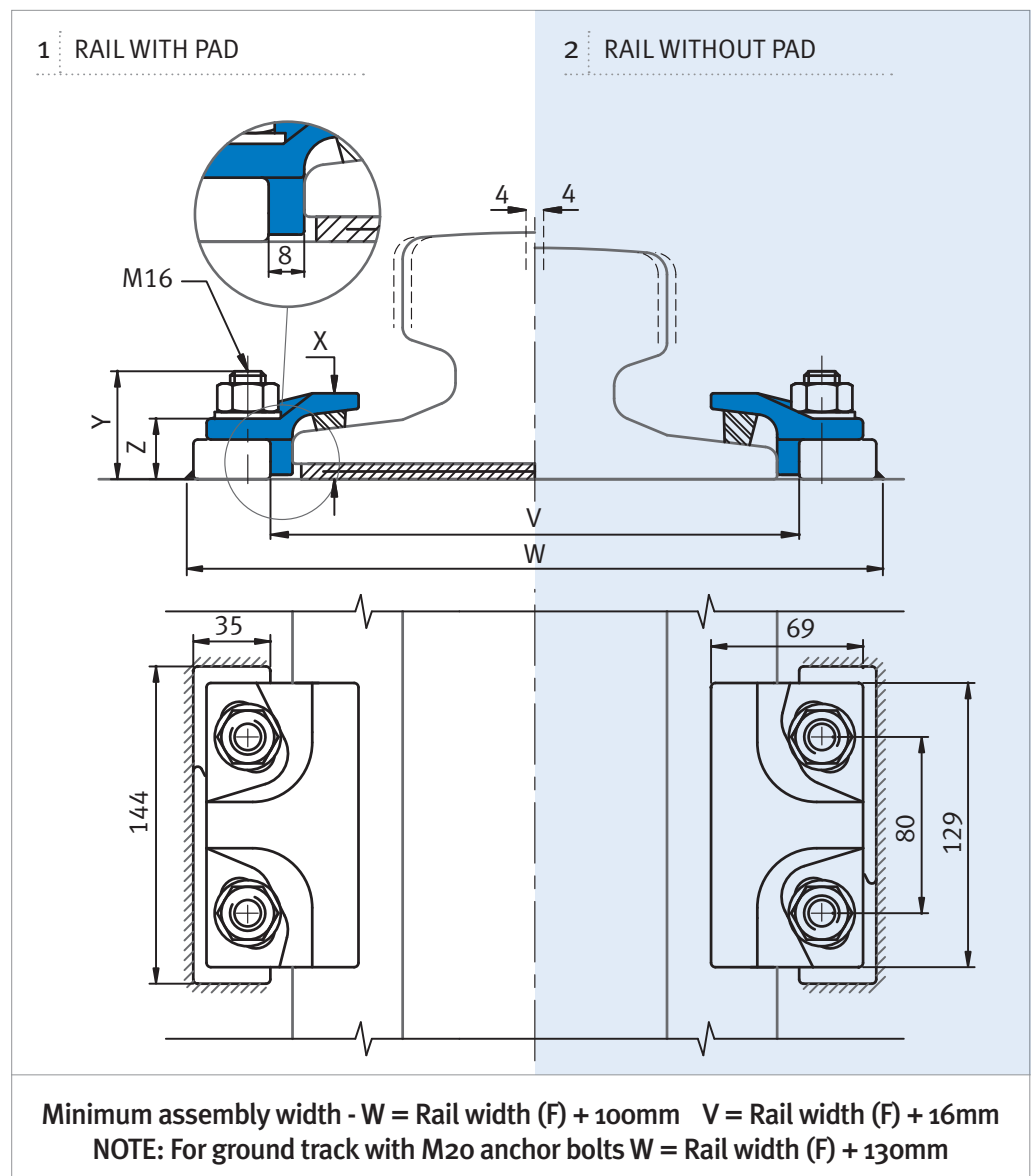

# 9216/08

## Gantrail Welded Base Fixing

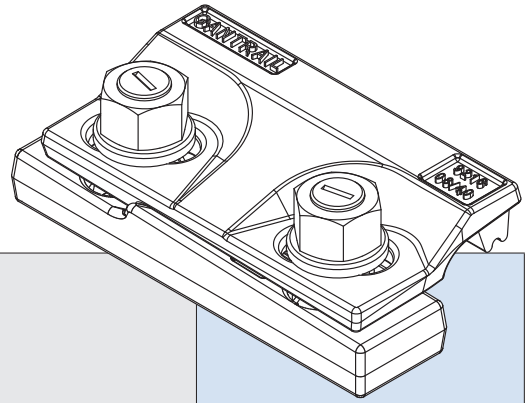

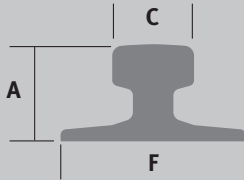
	F mm	C mm	A mm	1. CLIP REFERENCE FOR RAIL WITH PAD	2. CLIP REFERENCE FOR RAIL WITHOUT PAD
A75	200	75	85	9216/08/40	9216/08/40
A 100	200	100	95	9216/08/40	9216/08/40
A 120	220	120	105	9216/08/40	9216/08/40
S 49	125	67	149	9216/08/40	9216/08/40
S 54	125	67	154	9216/08/40	9216/08/40
56 E 1	140	70	159	9216/08/40	9216/08/40
89 kg CR	178	102	114	9216/08/44	9216/08/40
MRS 67 (135 CR)	132	79	146	9216/08/40	9216/08/40
MRS 86	165	102	102	9216/08/40	9216/08/40
MRS 87 A (PRI85R)	152	102	152	9216/08/44	9216/08/40
MRS 221	220	220	160	9216/08/44	9216/08/40
GCR 183	280	75	120	9216/08/40	9216/08/40
ISCR 80	130	82	130	9216/08/40	9216/08/40
ISCR 100	150	102	150	9216/08/40	9216/08/40
ISCR 120	170	120	170	9216/08/40	9216/08/40
QU 80	130	80	130	9216/08/40	9216/08/40
QU 100	150	100	150	9216/08/40	9216/08/40
QU 120	170	120	170	9216/08/40	9216/08/40
JIS 50N	127	64	153	9216/08/40	9216/08/40
JIS 60	145	64	174	9216/08/40	9216/08/40
CR 73	140	100	135	9216/08/40	9216/08/40
CR 100	155	120	150	9216/08/44	9216/08/40

**THIS CLIP CAN BE USED FOR A WIDER SELECTION OF RAILS THAN ILLUSTRATED.**

Please contact GANTRAIL for the full range of possible rails. All rails can be fastened with bolted or welded base clips. GANTRAIL may change or improve their products and also alter specifications without notice.

### INSTALLATION INSTRUCTIONS:

Weld along back and sides of clip base with a 5mm throat thickness fillet weld. Weld in 'V' with a 4mm throat thickness fillet weld. Use low hydrogen electrodes.

If a continuous weld around the clip base is required, this is possible. Please consult GANTRAIL for guidance.

**TIGHTENING TORQUE 125Nm**

Please contact GANTRAIL, for full installation instructions.

### WELD DETAIL

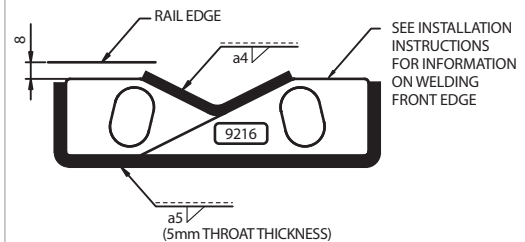

## A world of crane rail expertise.

[www.gantrail.com](http://www.gantrail.com)



**Gantry Railing Ltd**  
Sudmeadow Road  
Hempsted  
Gloucester GL2 5HG  
ENGLAND

Tel: +44 (0) 1452 300688  
Fax: +44 (0) 1452 300198  
E-mail: [info@gantrail.com](mailto:info@gantrail.com)

**Gantrail (Middle East) Ltd**  
P O Box 61428  
Jebel Ali Free Zone  
Dubai  
United Arab Emirates

Tel: +971 4 8812 935  
Fax: +971 4 8812 936  
E-mail: [gme@gantrail.com](mailto:gme@gantrail.com)



Certificate No. 5180