

9120/15

Gantrail Welded Base Fixing

www.gantrail.com



GANTRAIL
A world of crane rail expertise

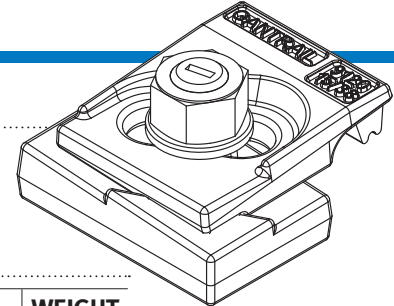

9120/15

The GANTRAIL 9120/15 adjustable crane rail clip is designed to fix heavy rails in the most arduous applications. It can withstand a horizontal force from the rail of 120kN (12.2 tonnes). Its low profile allows it to be used with cranes that are fitted with guide rollers.

SPECIFICATIONS:

MAX SIDE LOAD 120kN
15mm HORIZONTAL RAIL ADJUSTMENT

DIMENSIONS (mm):

REF NO.	X	Y (FULL NUT)	Y (THIN NUT)	Z	WEIGHT kg
9120/15/38	38	56	48	30	1.30
9120/15/41	41	56	48	30	1.33
9120/15/47	47	56	48	30	1.40

FEATURES

- The proven design has been used successfully for many years throughout the world.
- The clip is welded to the rail support. No access is required from below.
- The two main parts are locked together on tightening the grade 8.8 bolt.
- The clip has a self-tightening mechanism.
- A special vulcanised rubber block applies a controlled force to the rail.

COMPONENTS

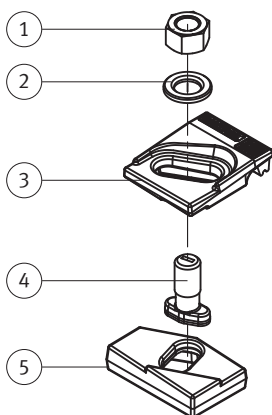

1. Nut
2. Hardened washer
3. Clip cap with integral rubber block
4. M20 Captive bolt
5. Weldable base

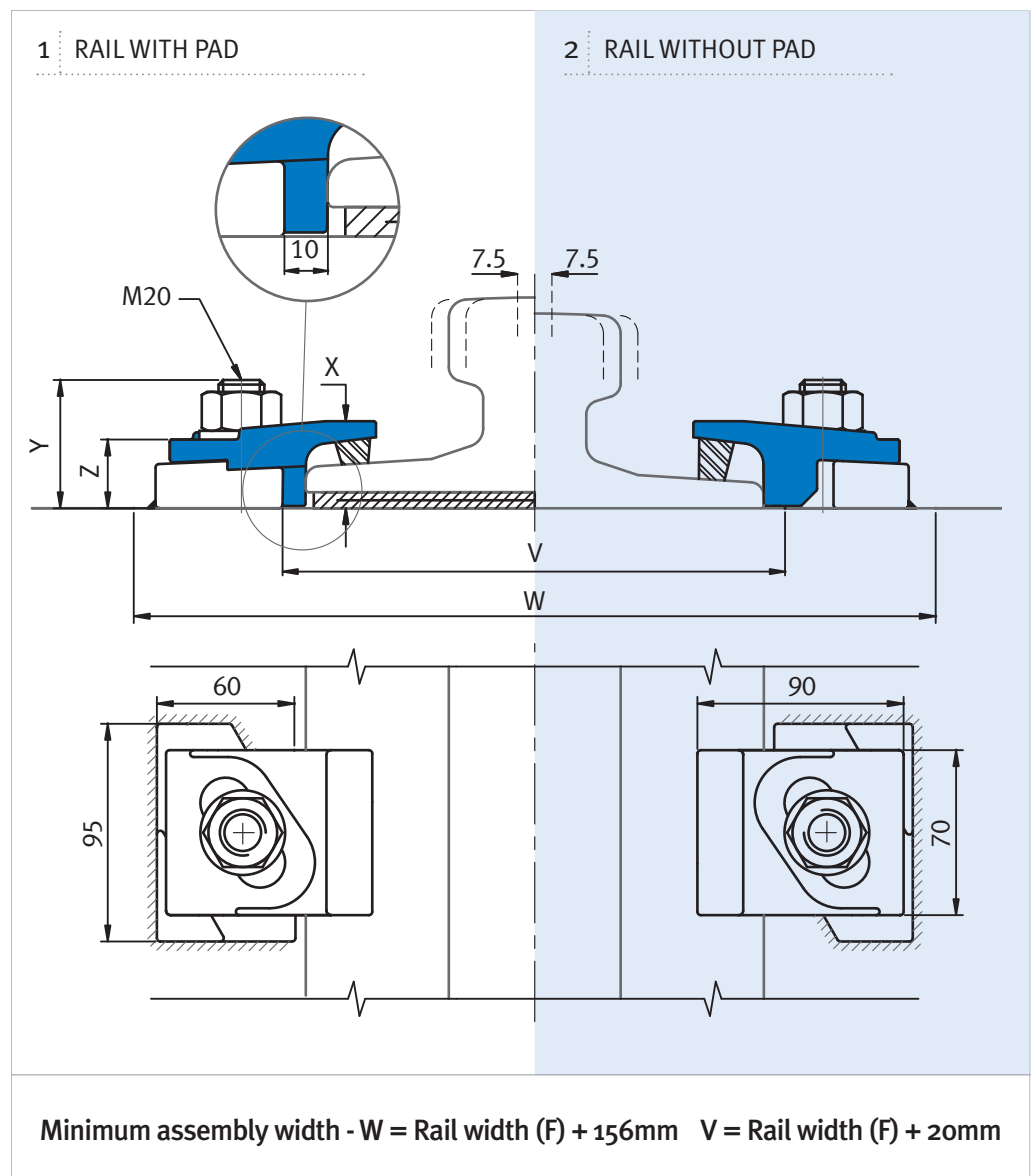

9120/15

Gantrail Welded Base Fixing

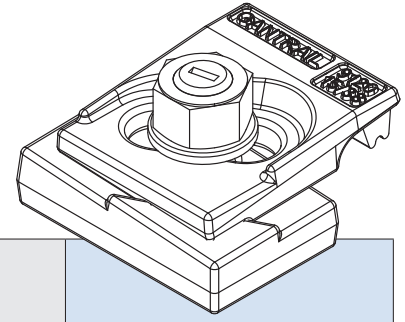

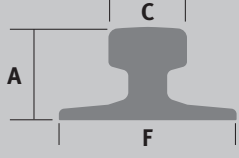
	F mm	C mm	A mm	1. CLIP REFERENCE FOR RAIL WITH PAD	2. CLIP REFERENCE FOR RAIL WITHOUT PAD
A 100	200	100	95	9120/15/38	9120/15/38
A 120	220	120	105	9120/15/38	9120/15/38
A 150	220	150	150	9120/15/38	9120/15/38
S 41	125	67	138	9120/15/38	-
S 49	125	67	149	9120/15/38	-
89 kg CR	178	102	114	9120/15/38	9120/15/38
MRS 67 (135 CR)	132	79	146	9120/15/38	9120/15/38
MRS 85 (171 CR)	152	103	152	9120/15/38	9120/15/38
MRS 86	165	102	102	9120/15/38	9120/15/38
MRS 87 A (PRI85R)	152	102	152	9120/15/38	9120/15/38
MRS 87 B (175 CR)	152	102	152	9120/15/38	9120/15/38
MRS 125	180	120	180	9120/15/47	9120/15/38
GCR 108	263	61 + 61	100	9120/15/38	-
GCR 183	280	75	120	9120/15/38	9120/15/38
ISCR 100	150	102	150	9120/15/38	9120/15/38
ISCR 120	170	120	170	9120/15/38	9120/15/38
QU 100	150	100	150	9120/15/38	9120/15/38
QU 120	170	120	170	9120/15/38	9120/15/38
JIS 50	127	63	145	9120/15/38	9120/15/38
JIS 60	145	64	174	9120/15/38	9120/15/38
CR 73	140	100	135	9120/15/38	9120/15/38
CR 100	155	120	150	9120/15/41	9120/15/38
68 kg AS	152	73	186	9120/15/38	9120/15/38
86 kg AS	165	102	102	9120/15/38	9120/15/38
UIC 54 E	125	66	161	9120/15/38	9120/15/38

THIS CLIP CAN BE USED FOR A WIDER SELECTION OF RAILS THAN ILLUSTRATED.

Please contact GANTRAIL for the full range of possible rails. All rails can be fastened with bolted or welded base clips. GANTRAIL may change or improve their products and also alter specifications without notice.

INSTALLATION INSTRUCTIONS:

Weld all round the clip base, except the side closest and parallel to the rail, with a 4mm throat thickness fillet weld, using low hydrogen electrodes.

If a continuous weld around the base is required, this is possible. Please consult GANTRAIL for guidance.

TIGHTENING TORQUE 250Nm

Please contact GANTRAIL, for full installation instructions.

WELD DETAIL

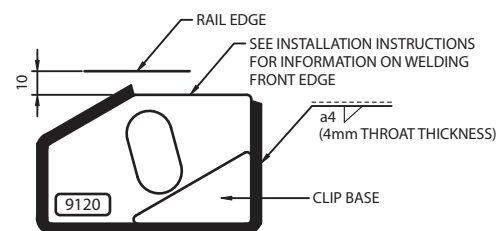

A world of crane rail expertise.

www.gantrail.com



Gantry Railing Ltd
Sudmeadow Road
Hempstead
Gloucester GL2 5HG
ENGLAND

Tel: +44 (0) 1452 300688
Fax: +44 (0) 1452 300198
E-mail: info@gantrail.com

Gantrail (Middle East) Ltd
P O Box 61428
Jebel Ali Free Zone
Dubai
United Arab Emirates

Tel: +971 4 8812 935
Fax: +971 4 8812 936
E-mail: gme@gantrail.com

