

1120/12

Gantrail Welded Base Fixing

www.gantrail.com

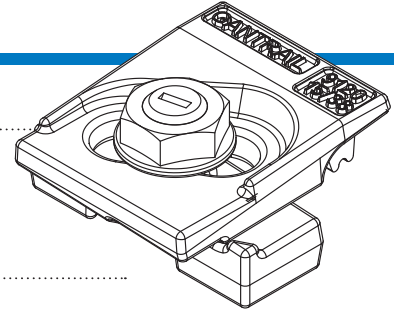

1120/12

The GANTRAIL 1120/12 adjustable crane rail clip is designed to fix heavy rails, on narrow supports, in the most arduous applications. It can withstand a horizontal force from the rail of 120kN (12.2 tonnes). Its low profile allows it to be used with cranes that are fitted with guide rollers.

SPECIFICATIONS:

MAX SIDE LOAD 120kN
12mm HORIZONTAL RAIL ADJUSTMENT

DIMENSIONS (mm):

REF NO.	X	Y	Z	WEIGHT kg
1120/12/38	38	48	30	0.90
1120/12/41	41	48	30	0.93

1120/12/38 COMPRISES 1120/12 BASE AND 9120/15/38 CAP
1120/12/41 COMPRISES 1120/12 BASE AND 9120/15/41 CAP

FEATURES

- The proven design has been used successfully for many years throughout the world.
- The clip is welded to the rail support. No access is required from below.
- The two main parts are locked together on tightening the grade 8.8 bolt.
- The clip has a self-tightening mechanism.
- A special vulcanised rubber block applies a controlled force to the rail.

COMPONENTS

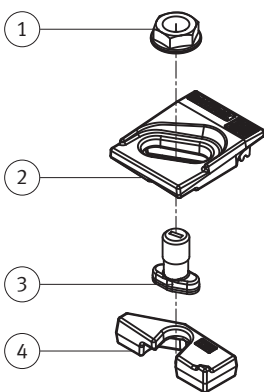

1. Flange nut
2. Clip cap with integral rubber block
3. M20 Captive bolt
4. Weldable base

1 RAIL WITH PAD

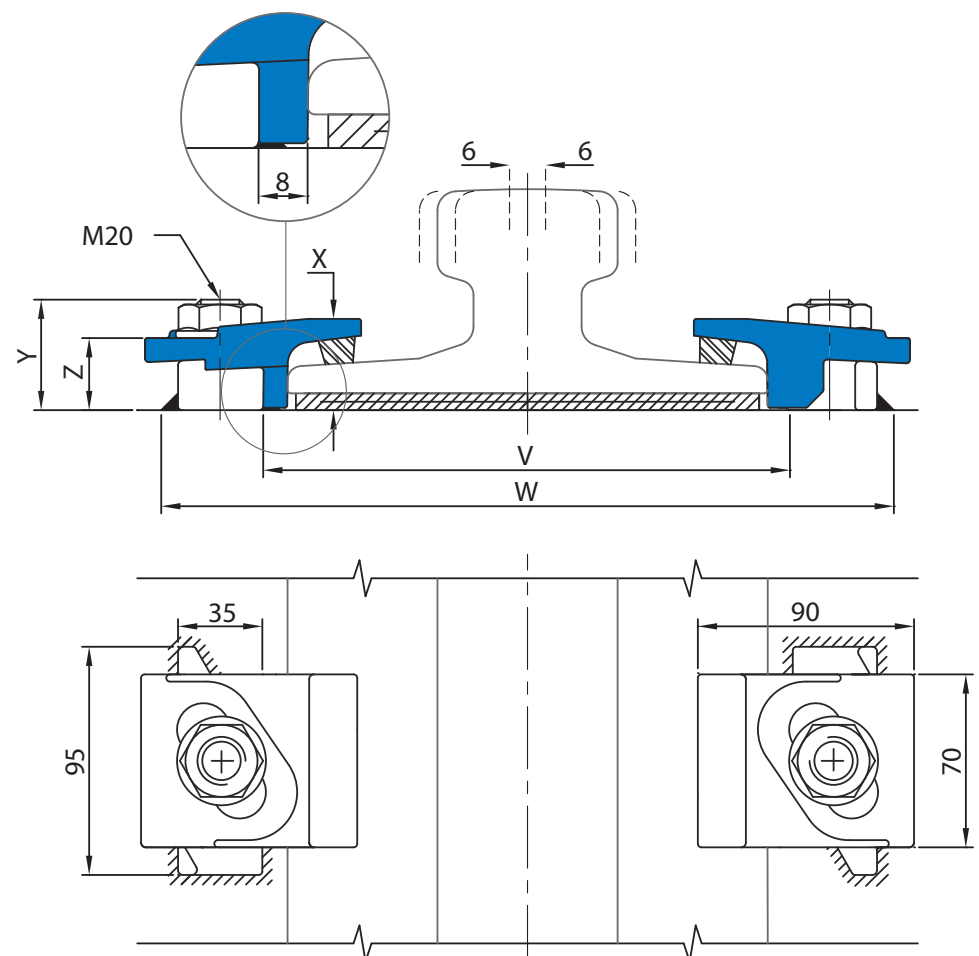

Minimum assembly width - $W = \text{Rail width (F)} + 100\text{mm}$ $V = \text{Rail width (F)} + 16\text{mm}$
NOTE: For ground track with M20 anchor bolts $W = \text{Rail width (F)} + 130\text{mm}$

1120/12

Gantrail Welded Base Fixing

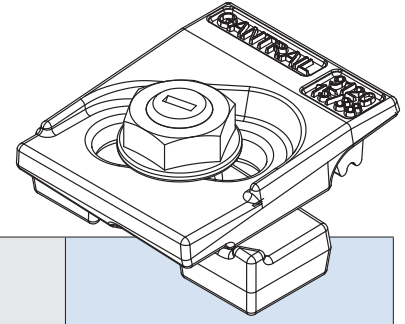

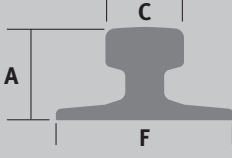
	F mm	C mm	A mm	1. CLIP REFERENCE FOR RAIL WITH PAD	2. CLIP REFERENCE FOR RAIL WITHOUT PAD*
A 100	200	100	95	1120/12/38	1120/12/38
A 120	220	120	105	1120/12/38	1120/12/38
A 150	220	150	150	1120/12/38	1120/12/38
S 41	125	67	138	1120/12/38	-
S 49	125	67	149	1120/12/38	-
89 kg CR	178	102	114	1120/12/38	1120/12/38
MRS 67 (135 CR)	132	79	146	1120/12/38	1120/12/38
MRS 85 (171 CR)	152	103	152	1120/12/38	1120/12/38
MRS 86	165	102	102	1120/12/38	1120/12/38
MRS 87 A (PRI85R)	152	102	152	1120/12/38	1120/12/38
MRS 87 B (175 CR)	152	102	152	1120/12/38	1120/12/38
GCR 108	263	61 + 61	100	1120/12/38	-
GCR 183	280	75	120	1120/12/38	1120/12/38
ISCR 100	150	102	150	1120/12/38	1120/12/38
ISCR 120	170	120	170	1120/12/38	1120/12/38
QU 100	150	100	150	1120/12/38	1120/12/38
QU 120	170	120	170	1120/12/38	1120/12/38
JIS 50	127	63	145	1120/12/38	1120/12/38
JIS 60	145	64	174	1120/12/38	1120/12/38
CR 73	140	100	135	1120/12/38	1120/12/38
CR 100	155	120	150	1120/12/41	1120/12/38
68 kg AS	152	73	186	1120/12/38	1120/12/38
86 kg AS	165	102	102	1120/12/38	1120/12/38
UIC 54 E	125	66	161	1120/12/38	1120/12/38

THIS CLIP CAN BE USED FOR A WIDER SELECTION OF RAILS THAN ILLUSTRATED.

Please contact GANTRAIL for the full range of possible rails. All rails can be fastened with bolted or welded base clips.

GANTRAIL may change or improve their products and also alter specifications without notice.

INSTALLATION INSTRUCTIONS:

Weld all round the clip base with a 5mm throat thickness fillet weld, using low hydrogen electrodes.

* For rail without pad, weld closest to and parallel with the rail must be omitted. Please consult Gantrail for guidance.

TIGHTENING TORQUE 350Nm

Please contact GANTRAIL, for full installation instructions.

WELD DETAIL

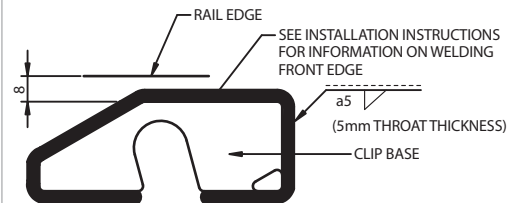

A world of crane rail expertise.

www.gantrail.com



Gantry Railing Ltd
Sudmeadow Road
Hempstead
Gloucester GL2 5HG
ENGLAND

Tel: +44 (0) 1452 300688
Fax: +44 (0) 1452 300198
E-mail: info@gantrail.com

Gantrail (Middle East) Ltd
P O Box 61428
Jebel Ali Free Zone
Dubai
United Arab Emirates

Tel: +971 4 8812 935
Fax: +971 4 8812 936
E-mail: gme@gantrail.com



Certificate No. 5180