

THIRD ANGLE PROJECTION

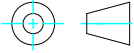

FOR GUIDANCE ONLY
THIS INFORMATION HAS BEEN
PROVIDED IN GOOD FAITH BUT
SPECIFICATIONS DO CHANGE

Edition A

Date 28/10/02

Scale 1:1 @ A4

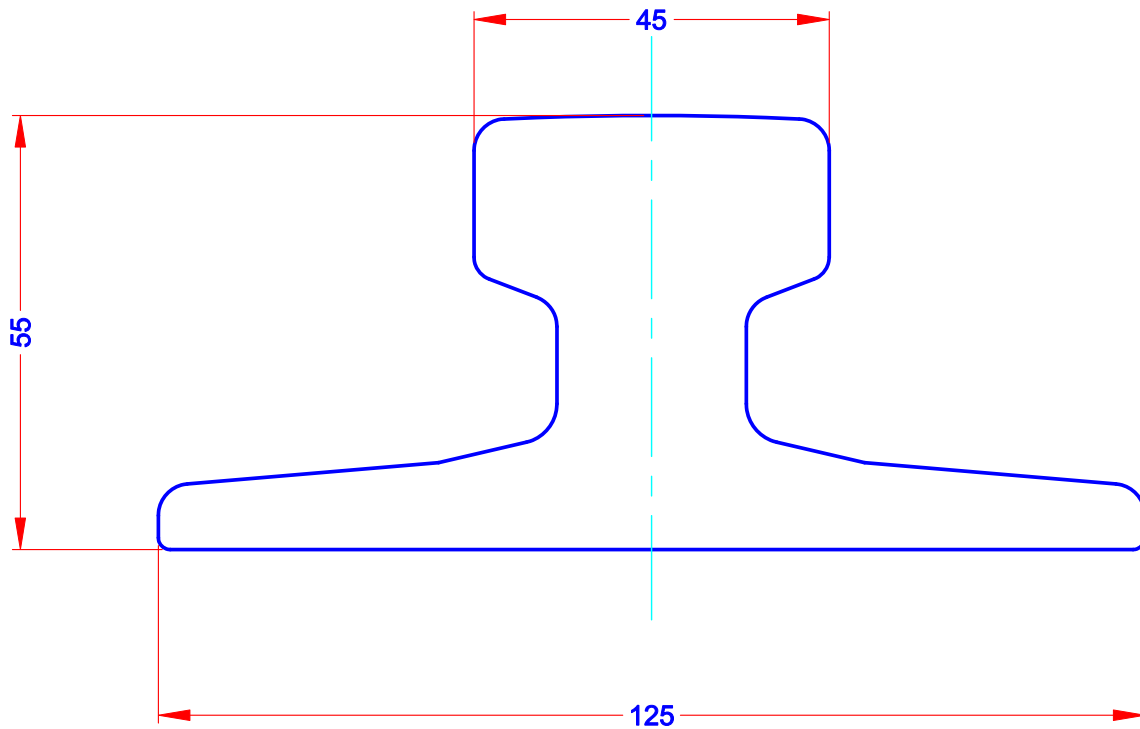

ASECOM[®]

Rail Mounting Systems

THE TECHNICAL DATA CONTAINED IN THIS DRAWING IS THE PROPERTY
OF ASECOM RAILS COMPANY AND IS SUBJECT TO COPYRIGHT ©

ASECOM RAILS

20, Rue Maurice Barrés
57175 GANDRANGE
Tel: 0033.962.074.366
Fax: 0033.387.586.279
Gsm: 0033.673.587.415

e-mail: contact@asecomrails.com

Rail Designation	A45
Rail Origin	CEE
Standard	DIN 536
Area of section	2824 mm ²
Calculated Mass	22.1 kg/m
Neutral Axis to base	21.8 mm
Moment of Inertia	I _{xx} 90 cm ⁴ I _{yy} 169 cm ⁴